

Il valore del tempo

La patina che si trova sul metallo vecchio non ha un colore proprio, ma è capace di rivelare gli infiniti colori che si nascondono da sempre nell'uniformità apparente delle superfici. Che si tratti di superfici lisce, ruvide o satinate, il lavoro dell'acqua, dell'ossidazione e del tempo stesso non indeboliscono la struttura, ma scavano invece carattere e bellezza nella materia.

The value of time

The patina that is found on the surface of old metal doesn't have a colour of its own, but it is able to exhibit an almost infinite amount of colours that are hidden under the apparent uniformity on the surface.

Be they smooth, structured or satin surfaces, the action of water, of oxidation and of time does not weaken the structure, but carve out character and beauty in the material itself.

Der Wert der Zeit

Die Patina auf altem Metall hat keine definierbare Farbe, aber sie enthüllt eine Vielfalt von Nuancen, die sich seit jeher in den scheinbaren einheitlichen Flächen verbergen. Gleichviel, ob diese glatt sind, rau oder matt: Wasser, Oxidation und die Zeit an sich schwächen die Struktur nicht, sondern formen Charakter und Schönheit des Materials.

La valeur du temps

Le voile recouvrant le vieux métal n'a pas de teinte réelle mais grâce à lui on peut retrouver la palette infinie de couleurs qui se dissimulent depuis toujours dans l'apparente uniformité chromatique des surfaces. Qu'il s'agisse de surfaces lisses, rugueuses ou satinées, l'effet de la détérioration provoqué par l'eau, de l'oxydation et du passer du temps-même n'affaiblissent pas la structure, mais exaltent, en revanche, le caractère et la beauté de la matière.

Ценность времени

У образующейся на старинных металлах патины нет своего цвета, но она способна раскрыть бесчисленные цвета, которые скрываются на безыскусных на первый взгляд поверхностях. Будь то речь о гладких, шероховатых или шелковистых поверхностях, действие воды, окисления, времени не ослабляет их структуру, а только вдыхает в материал еще больше характера, еще больше красоты.

Vitro

Iron

Allumina

Mint

Bronze

Corten

Dimensioni

Con TRACE, la scelta delle dimensioni delle piastrelle è un momento fondamentale per la definizione dei tuoi spazi. I diversi formati permettono infatti di creare effetti percettivi molto diversi: si può dare una direzione alle superfici, dare l'impressione che il tuo spazio sia parte di una costruzione molto più grande o sia esso stesso un monumento.

Dimensions

With TRACE, the choice of the size of the tile is a fundamental moment in defining your space. In fact, the various formats allow you to create perceived effects that are completely different: it can lead the surface down one particular direction, giving the impression that your space is part of a much bigger construction or even that it is a monument.

Formate

Mit TRACE ist die Formatwahl ein entscheidender Schritt für die Definition des Raums. Mit den einzelnen Fliesenformaten lassen sich sehr unterschiedliche optische Effekte erzielen: der Fläche kann eine Richtung gegeben werden, es kann der Eindruck entstehen, dass der Raum Teil eines sehr viel größeren Gebäudes ist oder dass er selbst ein Monument ist.

Dimensions

Le choix des dimensions des carreaux est un moment fondamentale pour la création de vos espaces; TRACE, avec ses différents formats, vous permet d'obtenir des effets et des perspectives très différentes d'un modèle à l'autre; l'effet directionnel que l'on retrouve sur la surface donne l'impression que votre espace fasse partie d'une construction bien plus grande, comme si c'était, lui-même, un monument.

Размеры

В случае коллекции TRACE выбор размера плитки является определяющим для формирования образа интерьера. Разные форматы позволяют создать совершенно разные перцептивные эффекты: можно наложить на поверхность направленный рисунок, а можно создать впечатление, что пространство является частью гораздо большего сооружения или что сам интерьер является своеобразным памятником.



120 x 240 cm



75 x 150 cm



25 x 150 cm



120 x 120 cm



75 x 75 cm



25 x 75 cm



60 x 60 cm



30 x 60 cm



30 x 30 cm



Senza Confini

Con i nuovi formati 120x240 e 120x120, il progetto Caesar di superfici per l'architettura cresce aprendo inedite prospettive. La riduzione delle fughe aumenta la percezione sensibile di ampiezza architettonica che si traduce in eleganza formale.



Floor
IRON 120 x 240

Wall
MINT 120 x 120
60 x 60
MINT DECO 60 x 60

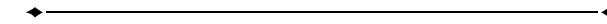

Space with no boundaries

With the new 120x240 and 120x120 sizes, Caesar project of surfaces for architecture opens up to new perspectives. The reduction of grout lines increases the perception of the architectural space that turns into pure elegance.

L'espace est sans limites

Avec les nouveaux formats 120x240 et 120x120, le projet Caesar des surfaces pour l'architecture se développe en offrant de nouvelles perspectives. La réduction des joints augmente la perception sensible de l'ampleur architecturale qui se traduit par une élégance formelle.

Räume ohne Grenzen

Die neuen Formate 120x240 und 120x120 eröffnen im Rahmen des Projekts architektonischer Flächen von Caesar völlig neue Perspektiven. Durch die Reduzierung der Fugen wird eine architektonischen Weite spürbar, die der Betrachter als formale Eleganz wahrnimmt.

Пространства без границ

Новые форматы 120x240 и 120x120 дополнили ассортимент Caesar, открыв совершенно новые дизайнерские перспективы. Меньшее количество швов визуально увеличивает пространство, придавая ему изумительную элегантность



Air

Ampiezza architettonica. Eleganza formale.

Architectural space. Pure elegance
 Ampleur architecturale. Élégnance formelle.
 Architektonischen Weite. Formale Eleganz
 Увеличивает пространство. Изумительную
 элегантность.



Floor
IRON 120 x 240

Wall
MINT 120 x 240
 120 x 120
 60 x 60
MINT DECO 60 x 60

Living

◆————◆

Una composizione preziosa e vivente.

A precious and living composition.
Un'ambiançe précieuse et vive.
Eine kostbare, lebendige Komposition.
Ценная и полная жизни композиция.



Floor
ALLUMINA 75 x 75 iridescent

TRACE



Floor
ALLUMINA 75 x 75 iridescent



Floor
ALLUMINA 75 x 75 iridescent

Clear

◆————◆

Mille sfumature plasmate da linee pulite.

Thousands of hues fashioned by clear lines.
Milles nuances grâce à des lignes très épurées.
Tausend durch klare Linien geformte Nuancen.
Тысячи нюансов, сплетенных из чистых линий.



Floor
BRONZE 75 x 75 naturale

Wall
BRONZE 25 x 75 iridescent
MINT COMPOSIZIONE A 30 x 30
LIFE OAK 20 x 120



Floor
BRONZE 75 x 75 naturale

Wall
BRONZE 25 x 75 iridescent
MINT COMPOSIZIONE A 30 x 30
LIFE OAK 20 x 120

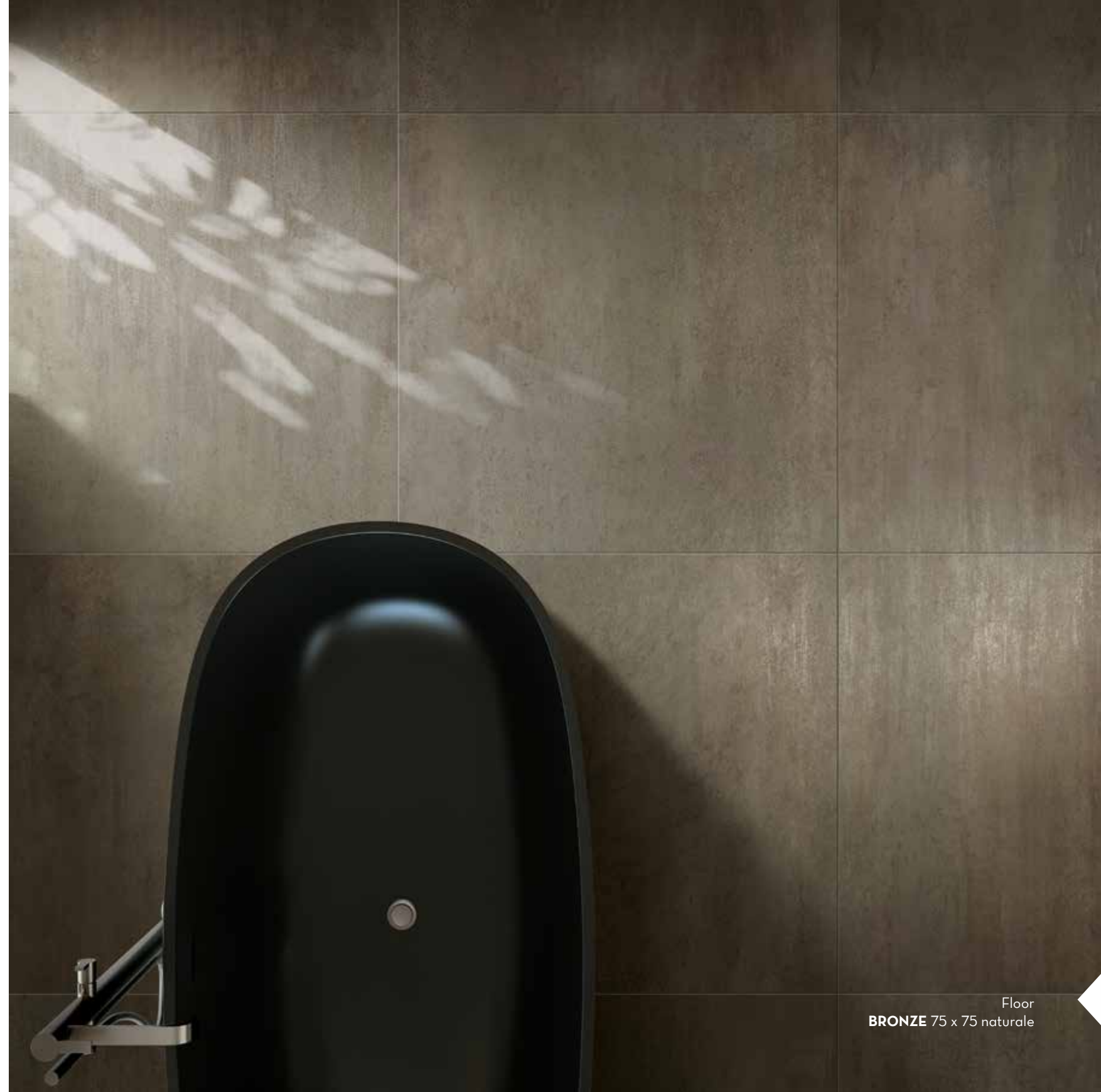

Floor
BRONZE 75 x 75 naturale

Urban

◆————◆

Uno spazio in trasformazione.

A space in transformation.
Un espace en évolution.
Im Wandel begriffener Raum.
Динамичное пространство.



Floor
IRON 75 x 150 naturale
CORTEN 75 x 150 naturale

Wall
CORTEN 75 x 150 naturale
ALLUMINA 75 x 150 naturale

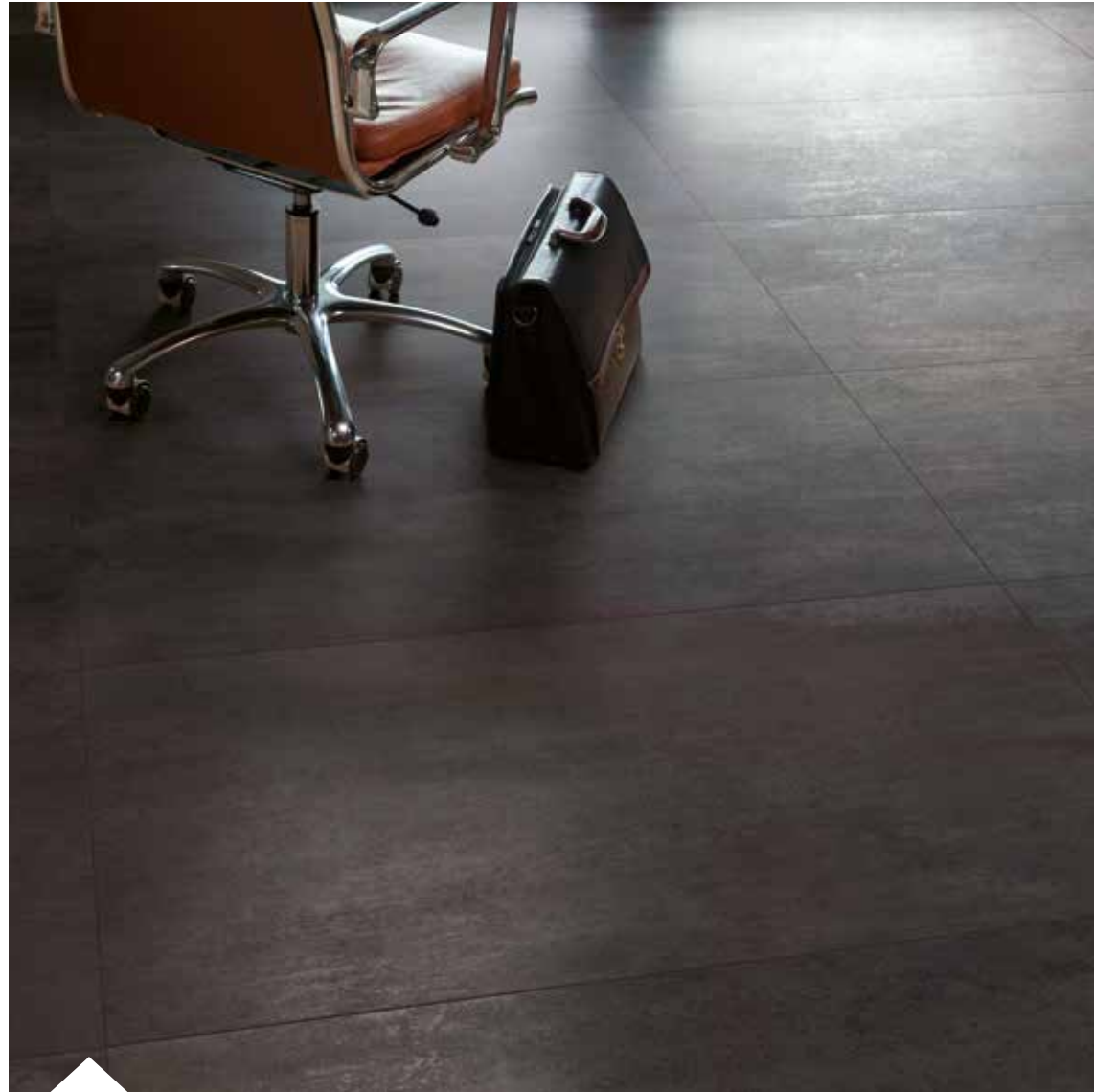

Floor
IRON 75 x 150 naturale



Floor
IRON 75 x 150 naturale
Wall
MINT DECO 60

Fresh

Una personalità originale. Un'atmosfera unica.

An original character. A unique atmosphere.
Un caractère original. Une atmosphère unique.
Originelle Persönlichkeit. Einzigartige Atmosphäre.
Оригинальный характер. Уникальная атмосфера.

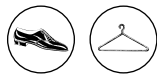

TRACE

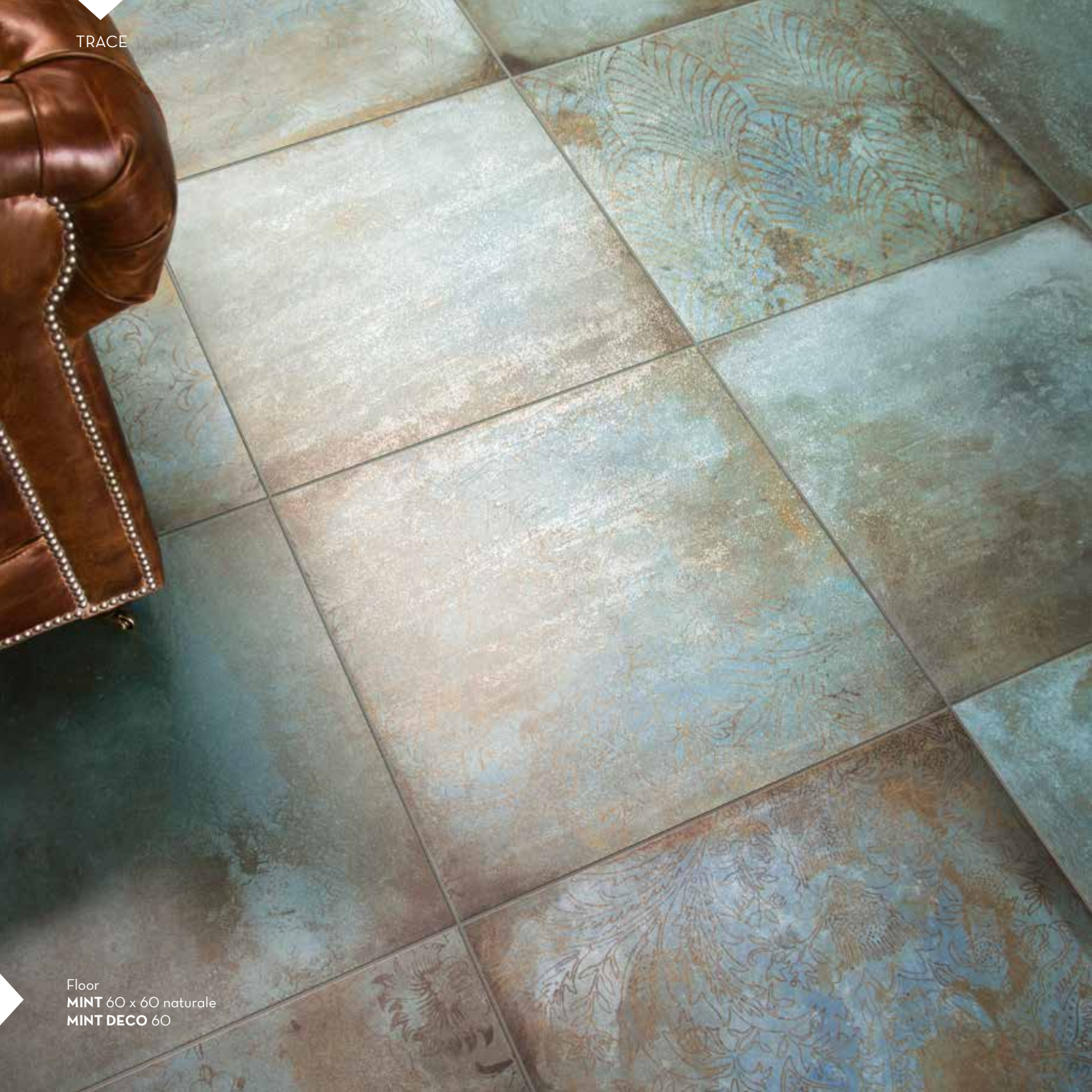

Floor
MINT 60 x 60 naturale
MINT DECO 60



Floor
MINT 60 x 60 naturale
MINT DECO 60

Idea

Un gioco di riflessi e opacità.

A play of reflections and opacity.
Un jeu de reflets et d'opacités.
Ein Spiel aus Reflexen und Opazität.
Игра блеска и матовости.



Floor
CORTEN 75 x 150 naturale

Wall
MINT DECO 30
IRON 25 x 150 naturale

TRACE



Floor
CORTEN 75 x 150 naturale

Wall
MINT DECO 30

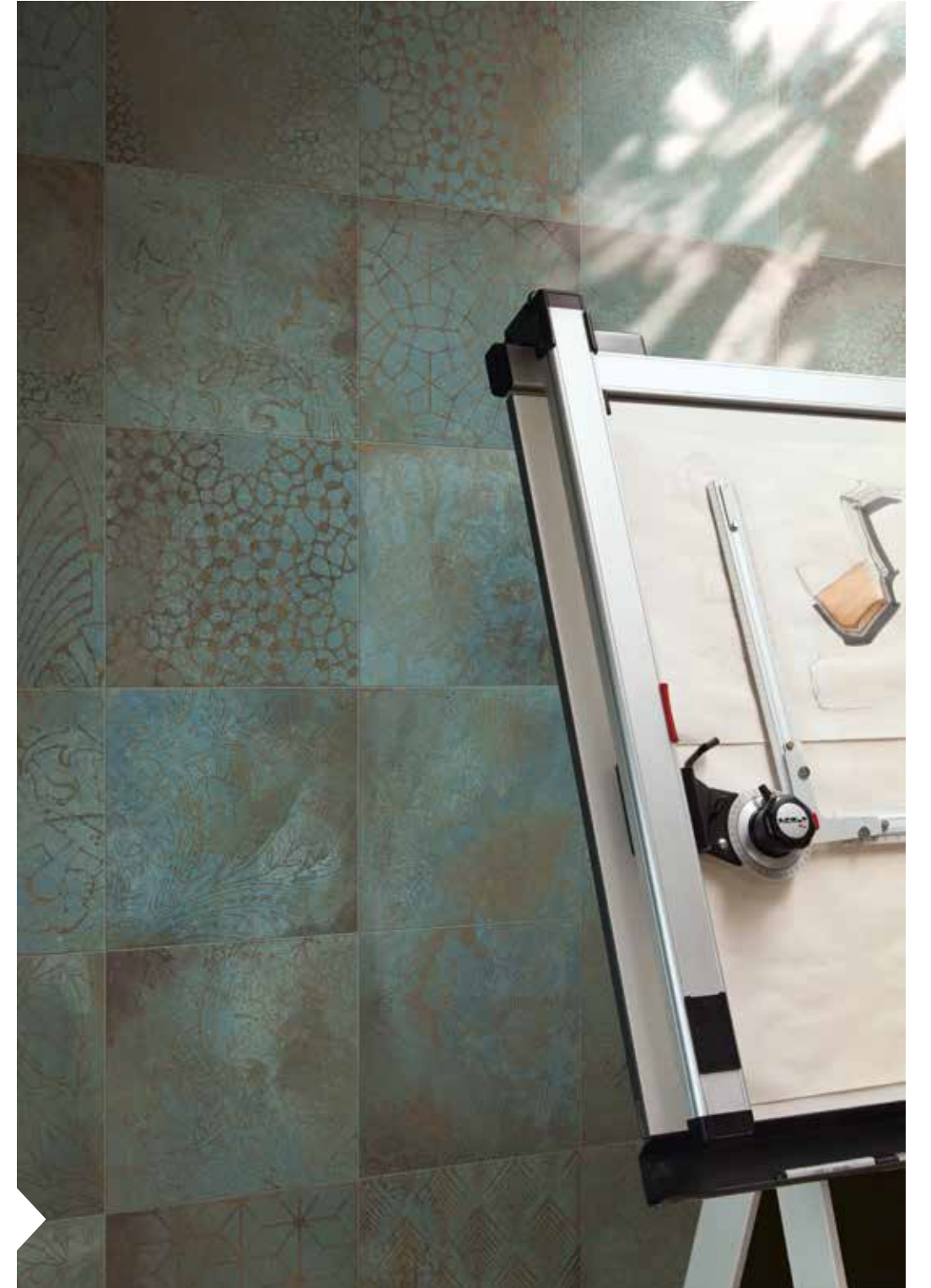

Luxury

◆————◆

Unico. Elegante. Memorabile.

Unique. Elegant. Memorable.
Unique. Elégant. Eternel.
Einzigartig. Elegant. Denkwürdig.
Уникально. Элегантно. Незабываемо.



Floor
VITRO 75 x 75 naturale
Wall
BRONZE iridescent

TRACE



Floor
VITRO 75 x 75 naturale

Wall
BRONZE iridescent



Outdoor

◆————◆

Un monumento allo stile.

A monument to style.
Une reconnaissance au style.
Ein Denkmal für den Stil.
Памятник стилю.



“Olson Kundig Architects”



Wall
CORTEN 75 x 150 naturale

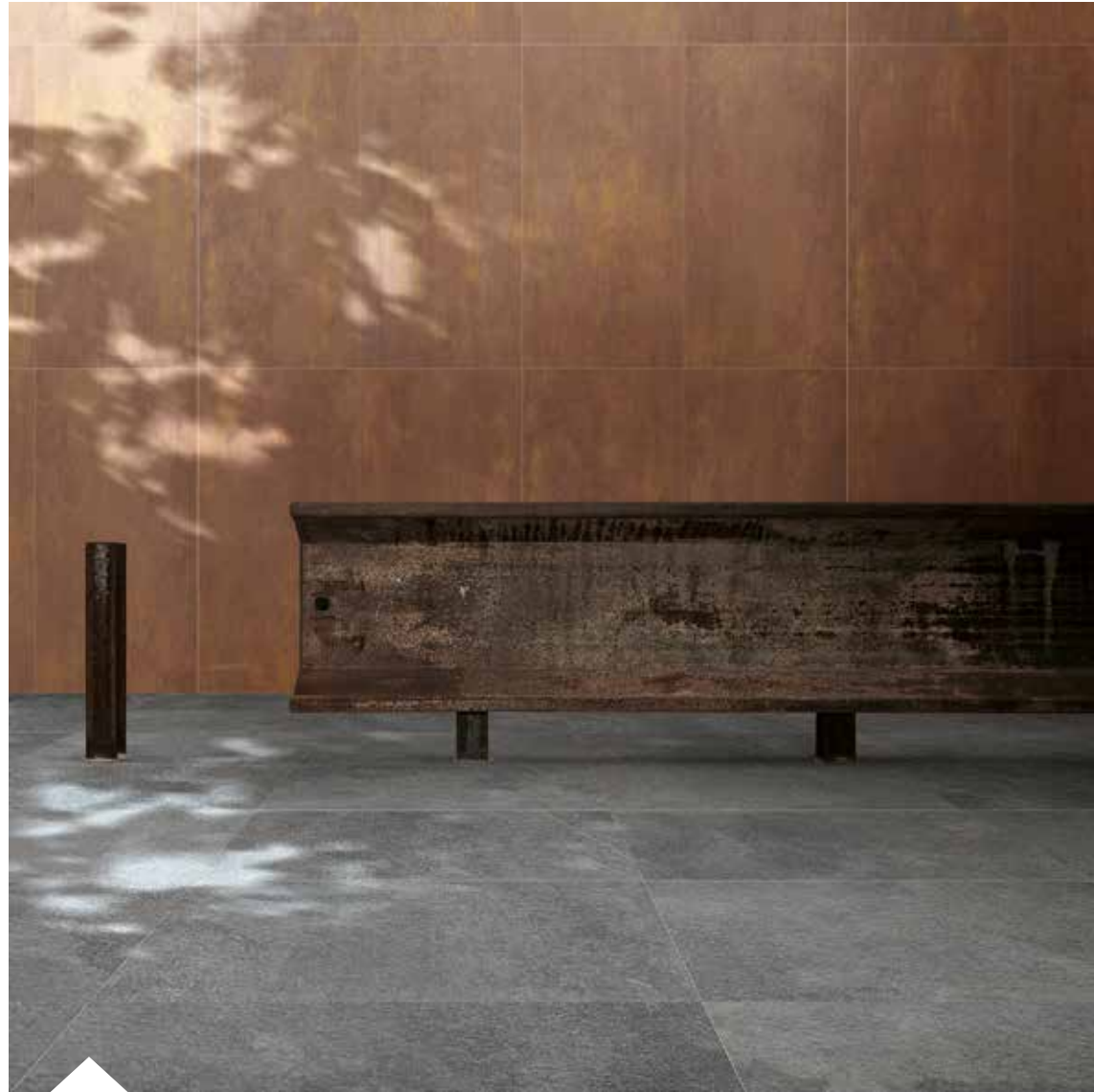

Floor
EIKON AERAS 45 x 90 xt 
Wall
CORTEN 75 x 150 naturale



Floor
EIKON AERAS 45 x 90 xt 
Wall
CORTEN 75 x 150 naturale

Where

Plus



RIVESTIMENTO

Wall
Revêtement
Wandbelag
Настенная плитка



PAVIMENTO

Floor
Sol
Boden
Напольная плитка



RIVESTIMENTO OUTDOOR

Outdoor wall
Revêtement d'extérieur
Wandbelag für Außenbereiche
Плитка для наружных пространств



RESIDENZIALE

Residential
Résidentiel
Wohnbereich
Жилые пространства



COMMERCIALE

Retail Space
Commercial
Gewerblicher Bereich
Коммерческие пространства



UFFICIO

Office
Bureau
Büro
Офисы

1



RESISTENZA ALLA FLESSIONE

Bending strength
Résiste à la flexion
Biegefest
Прочность на изгиб

2



BASSA ASSORBENZA

Low absorbency
Peu absorbant
Geringe Wasseraufnahme
Низкое водопоглощение

3



RESISTENZA A GRAFFI E ABRASIONI

Resistance to scratches and abrasion
Résiste aux rayures et à l'abrasion
Kratz- und abriebfest
Стойкость к царапинам и износу

4



RESISTENTE A MACCHIE ED ATTACCHI CHIMICI

Resistance to stain and chemicals
Résiste aux taches et aux agressions chimiques
Fleck- und chemikalienbeständig
Стойкость к загрязнениям и химикатам

5



FACILMENTE PULIBILE

Easy cleaning
Nettoyage facile
Reinigungsfreundlich
Легкость чистки

6



RESISTENTE AL GELO E AGLI SBALZI TERMICI

Resistance to frost and thermal shock
Résiste au gel et aux écarts de température
Temperaturwechsel- und frostbeständig
Стойкость к морозам и температурным перепадам

VITRO

Formati / Sizes / Formats / Formate / Форматов



119,5 x 119,5
47 1/16" x 47 1/16"

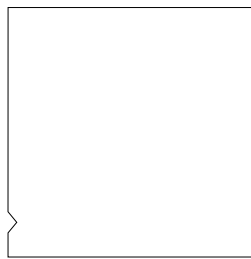

Iridescent, monocalibro, rettificato e squadrato.
Iridescent, rectified, squared, one caliber.
Iridescent, monocalibre, rectifié et mis d'équerre.
Iridescent, ein kaliber, rektifiziert und rechtwinkelig.
Иридисцент, ретифицированная, одного калибра.



25 x 150
9 13/16" x 59 1/16"



25 x 75
9 13/16" x 29 9/16"



Naturale, monocalibro, rettificato e squadrato.
Matt, rectified, squared, one caliber.
Naturel, monocalibre, rectifié et mis d'équerre.
Natur, ein kaliber, rektifiziert und rechtwinkelig.
Матовая, ретифицированная, одного калибра.



30 x 60
11 13/16" x 23 5/8"



Cover

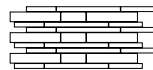

30 x 60
11 13/16" x 23 5/8"



119,5 x 239
47 1/16" x 94 1/8"

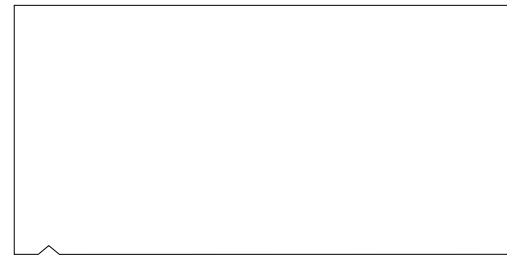

75 x 150
29 9/16" x 59 1/16"

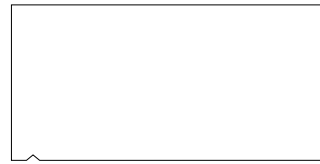

75 x 75
29 9/16" x 29 9/16"

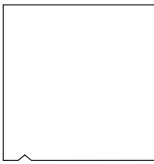

60 x 60
23 5/8" x 23 5/8"

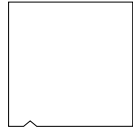

Composizione A



30 x 30
11 13/16" x 11 13/16"

ALLUMINA

Formati / Sizes / Formats / Formate / Форматов



119,5 x 119,5
47 1/16" x 47 1/16"

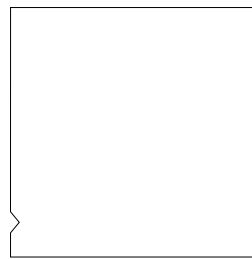

25 x 150
9 13/16" x 59 1/16"



25 x 75
9 13/16" x 29 9/16"



30 x 60
11 13/16" x 23 5/8"



Cover

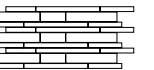

30 x 60
11 13/16" x 23 5/8"



75 x 150
29 9/16" x 59 1/16"



75 x 75
29 9/16" x 29 9/16"

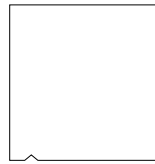

60 x 60
23 5/8" x 23 5/8"

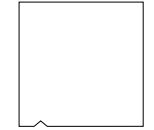

Composizione A





30 x 30
11 13/16" x 11 13/16"

**BRONZE**

Formati / Sizes / Formats / Formate / Форматов



 **Iridescent, monocalibro, rettificato e squadrato.**
Iridescent, rectified, squared, one caliber.
Iridescent, monocalibre, rectifié et mis d'équerre.
Iridescent, ein kaliber, rektifiziert und rechtwinkelig.
Иridescent, ретифицированная, одного калибра.

 **Naturale, monocalibro, rettificato e squadrato.**
Matt, rectified, squared, one caliber.
Naturel, monocalibre, rectifié et mis d'équerre.
Natur, ein kaliber, rektifiziert und rechtwinkelig.
Матовая, ретифицированная, одного калибра.



25 x 75
9 13/16" x 29 9/16"



30 x 60
11 13/16" x 23 5/8"

Cover

30 x 60
11 13/16" x 23 5/8"

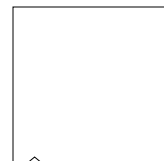

75 x 75
29 9/16" x 29 9/16"

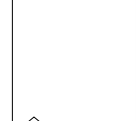

60 x 60
23 5/8" x 23 5/8"

Composizione A

30 x 30
11 13/16" x 11 13/16"

CORTEN

Formati / Sizes / Formats / Formate / Форматов



25 x 150
9 13/16" x 59 1/16"



25 x 75
9 13/16" x 29 9/16"

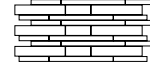

30 x 60
11 13/16" x 23 5/8"

Cover

30 x 60
11 13/16" x 23 5/8"



75 x 150
29 9/16" x 59 1/16"

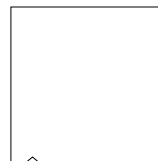

75 x 75
29 9/16" x 29 9/16"

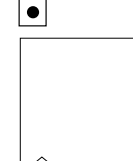

60 x 60
23 5/8" x 23 5/8"

Composizione A

30 x 30
11 13/16" x 11 13/16"



IRON

Formati / Sizes / Formats / Formate / Форматов

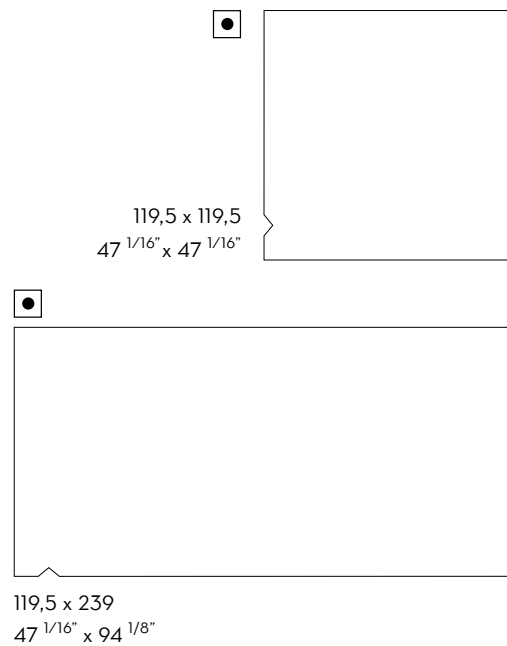
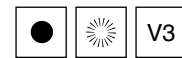

Iridescent, monocalibro, rettificato e squadrato.
Iridescent, rectified, squared, one caliber.
Iridescent, monocalibre, rectifié et mis d'équerre.
Iridescent, ein kaliber, rektifiziert und rechtwinkeling.
Iridescent, ретифицированная, одного калибра.

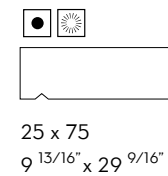
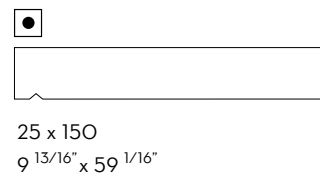

Naturale, monocalibro, rettificato e squadrato.
Matt, rectified, squared, one caliber.
Naturel, monocalibre, rectifié et mis d'équerre.
Natur, ein kaliber, rektifiziert und rechtwinkeling.
Матовая, ретифицированная, одного калибра.

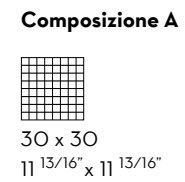
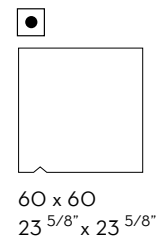
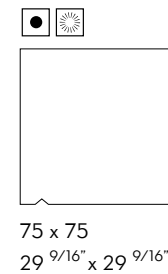
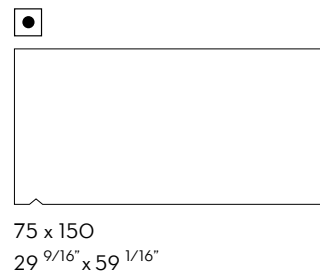
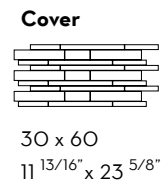
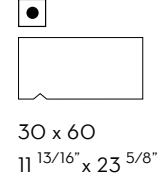

MINT

Formati / Sizes / Formats / Formate / Форматов

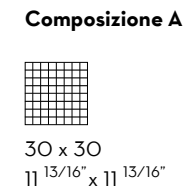
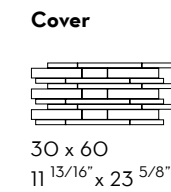
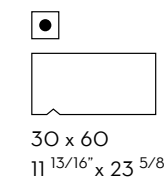
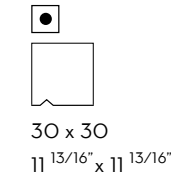
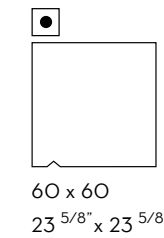
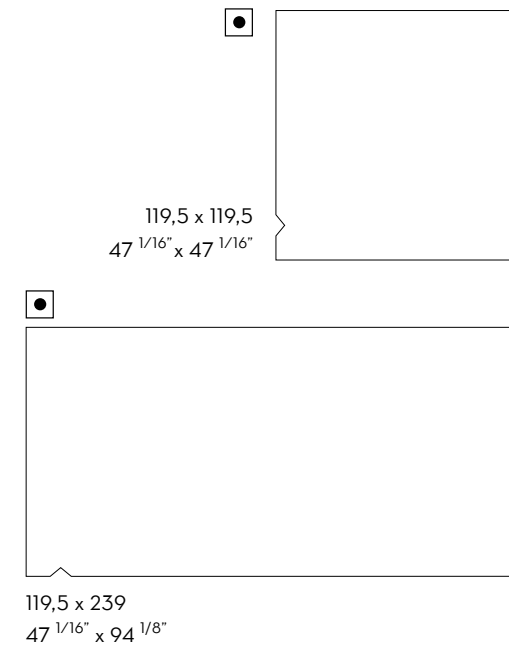
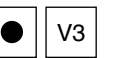

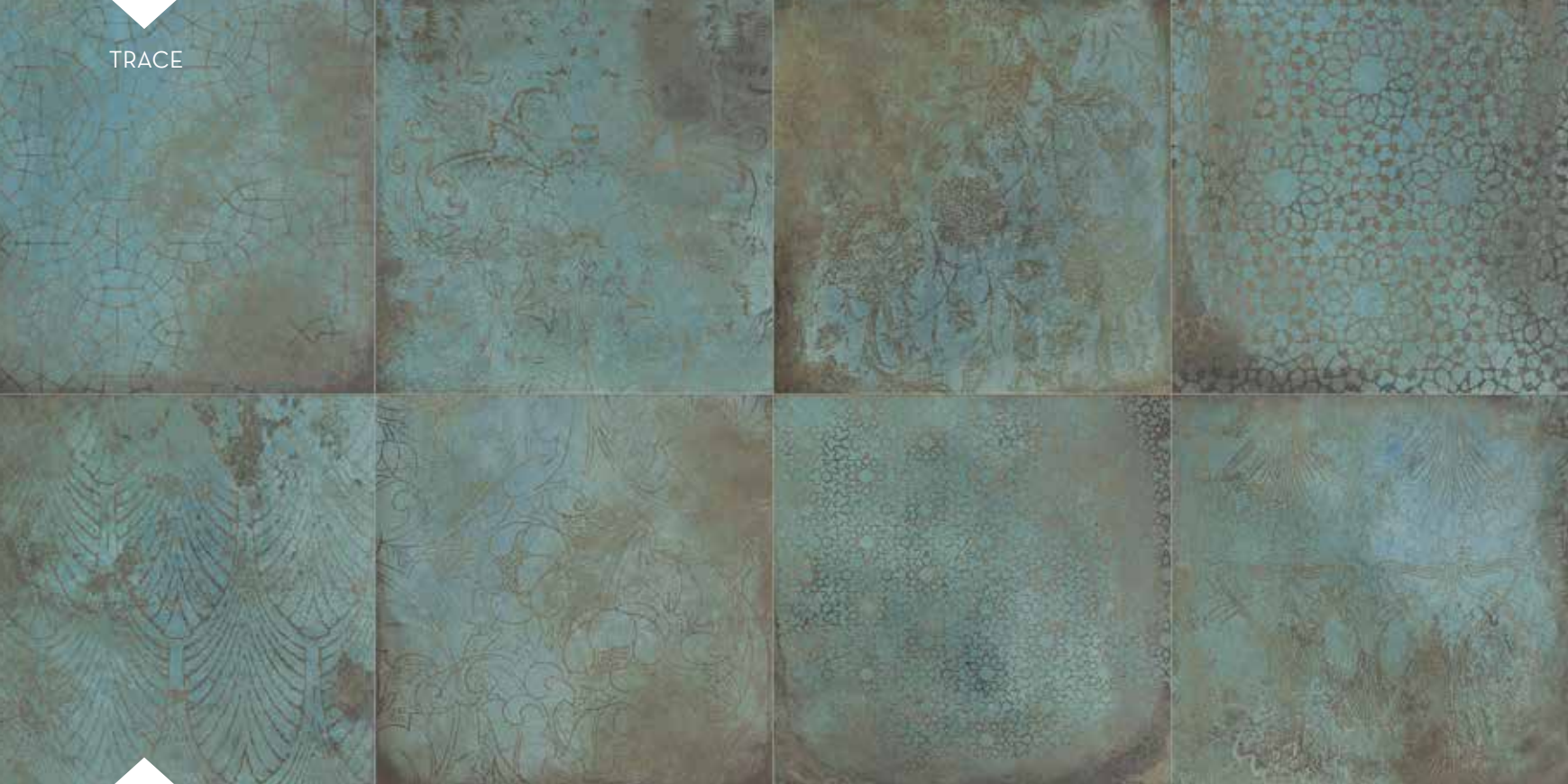

TRACE

MINT DECO

Formati / Sizes / Formats / Formate / Форматов

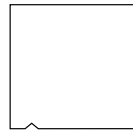

60 x 60
23 5/8" x 23 5/8"



30 x 30
11 13/16" x 11 13/16"

***Tagliato dal formato 60x60.**
Cut from the 60x60 cm size.
Découpé au format 60x60.
Aus dem Format 60x60 zugeschnitten.
Вырезано из формата 60x60 см.

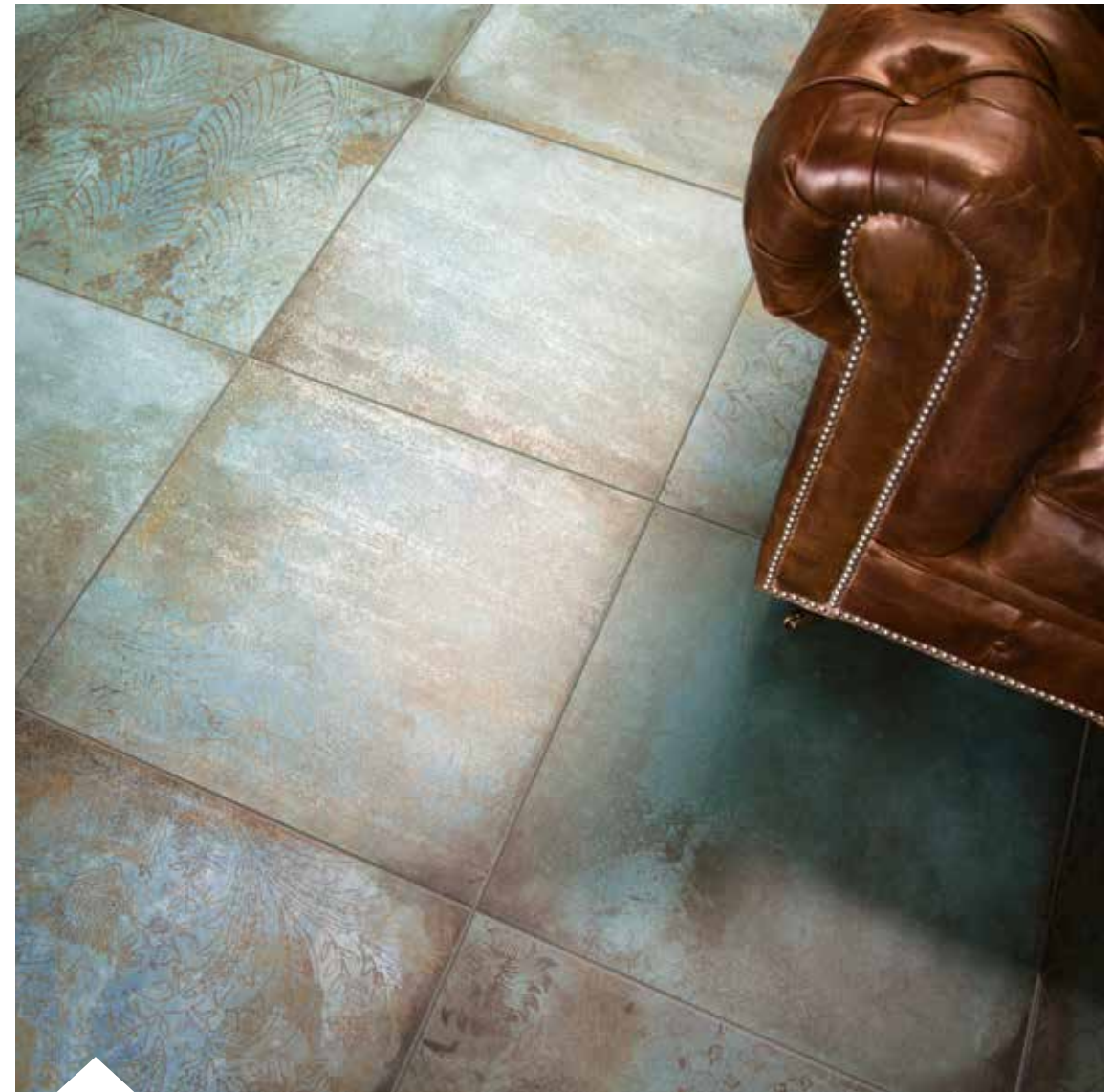
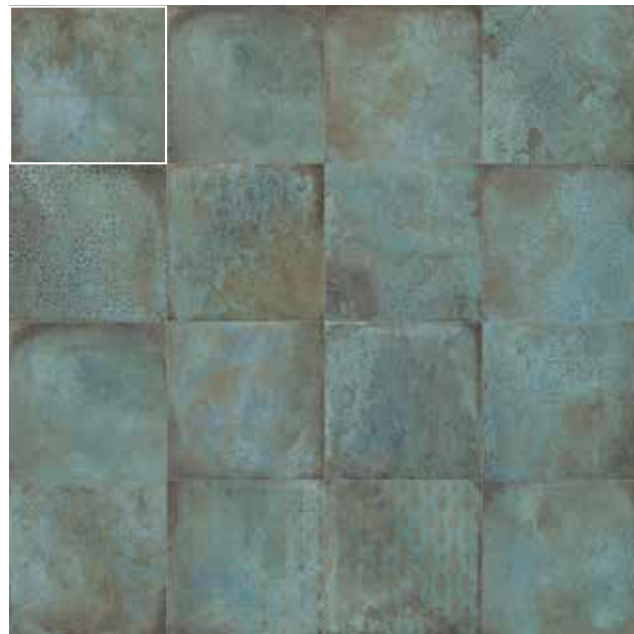

Floor
MINT 60 x 60 naturale
MINT DECO 60